

Quiz Project

This project can be used for a quiz with up to 4 contestants (or teams). Each contestant has a trigger push-switch and LED. When a trigger switch is pressed it lights the corresponding LED, sounds the bleeper and prevents the other trigger switches from working - therefore showing which contestant was the first to press their switch. A reset push-switch (operated by the quizmaster) cancels the bleeper and switches off the LED so the circuit is ready for the next question.

Take great care to arrange the parts correctly on the compact stripboard layout. The LEDs are shown mounted directly on the stripboard but you may prefer to mount them on a box using short wires. The trigger switches need long cables of about 2 metres so they can be held by, or placed near, the contestants.

The circuit consists of four 555 timer bistables which are triggered or reset when their inputs are low. Their reset inputs are connected together and operated by a single reset push-switch. The trigger switches are connected to the bistable trigger (pin 2) through a $0.1\mu\text{F}$ capacitor so that only the initial press triggers the bistable; continuing to hold the switch closed will have no effect. Connecting the switch directly to the bistable would prevent the quizmaster from resetting the circuit until the trigger switch was released and trials showed that many contestants kept the switch pressed until asked to give their answer! When triggered the bistable output (pin 3) lights an LED and makes the 'trigger line' high - this prevents any other bistable being triggered and sounds the bleeper. A diode is used to link the output to the trigger line.

Parts Required

- resistors: 470 \times 4, 1k \times 2, 10k \times 8
- capacitors: $0.1\mu\text{F}$ \times 4, $1\mu\text{F}$ radial
- diodes: 1N4148 \times 4
- battery clip for 9V PP3
- bleeper suitable for 3 to 6V
- stripboard: 10 rows \times 50 holes
- 555 timer ICs (such as NE555) \times 4
- 8-pin DIL sockets for ICs \times 4
- on/off switch
- push-switch \times 5
- LEDs: 1 each red, green, yellow, blue, all 5mm
- 2-core cable (eg 'figure 8') about 8 metres.

Stripboard Layout

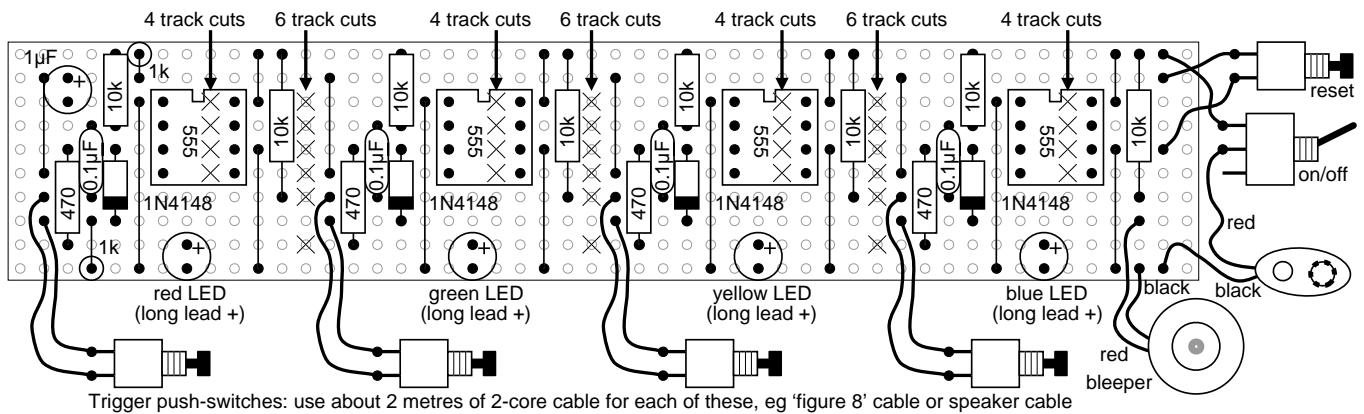

Circuit Diagram

