

Computer Network Lead Tester Project

This project was designed for confirming the continuity and correct wiring of computer network leads which have 8 wires, but it can be used to check any lead with up to 8 wires by using appropriate connectors. For example stereo audio leads with 5-pin DIN plugs can be checked by just using the first 5 LEDs. The tester is simple but it can save a great deal of time when making up leads and it is much cheaper than the more sophisticated alternatives!

The tester works by connecting each wire to an output at one end and an LED at the other end. The outputs are switched on one at a time in sequence so that a correctly wired lead will make each LED light in turn. The 4017 IC counts up to 10 so there is a pause (for the 9th and 10th counts) before the LED sequence repeats. If the LEDs light up in the wrong sequence one (or both) of the connectors is wired wrongly. If an LED fails to light it indicates a broken connection. Please note that the RJ45 computer network plugs cannot normally be re-wired, instead they must be cut off and replaced.

Parts Required

- resistors: 2.2k, 22k, 180k, 560 × 8
- capacitors: 0.1µF, 1µF 16V radial × 2
- red LEDs × 8
- push switch
- stripboard: 16 rows × 19 holes
- RJ45 computer network sockets × 2 (a dual socket for example) (or choose suitable connectors for the leads you wish to test)
- 555 timer IC
- 4017 counter IC
- DIL sockets for ICs: 8-pin, 16-pin
- battery clip for 9V PP3

Stripboard Layout

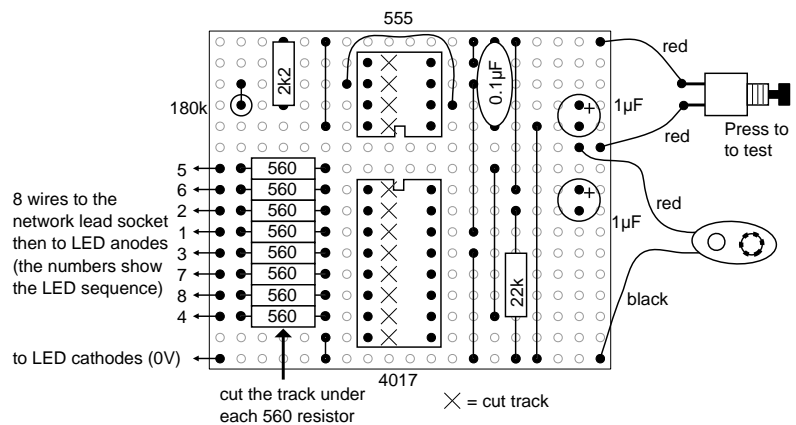

Each socket should be wired up in the same way, so that wire 1 from the stripboard connects to pin 1 on the first socket, and pin 1 on the second socket connects to LED 1.

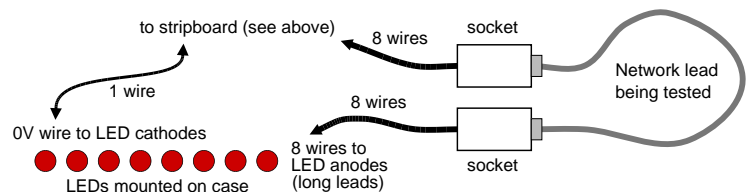

Circuit diagram

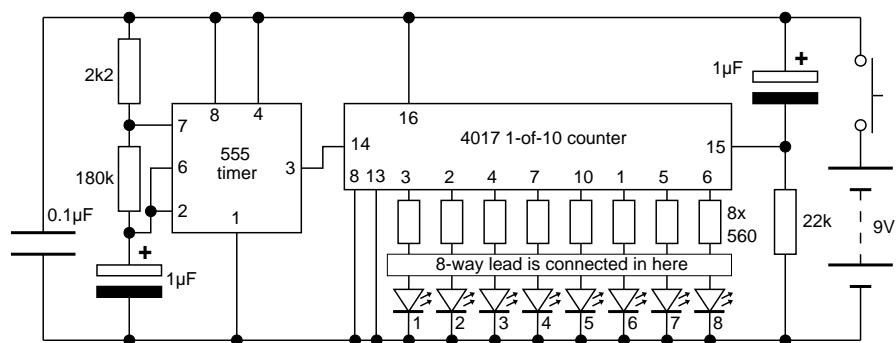

If the lead is OK each LED should light up in sequence from left to right (1 to 8 above).